

# MITER 1000<sup>HD</sup>™ by INCRA®

## OWNER'S MANUAL

BEFORE USING THE **INCRA MITER1000HD**, READ AND FOLLOW ALL OF THE INSTRUCTIONS AND SAFETY INFORMATION IN THIS OWNER'S MANUAL.

**HIGH DEFINITION** FROM INCRA

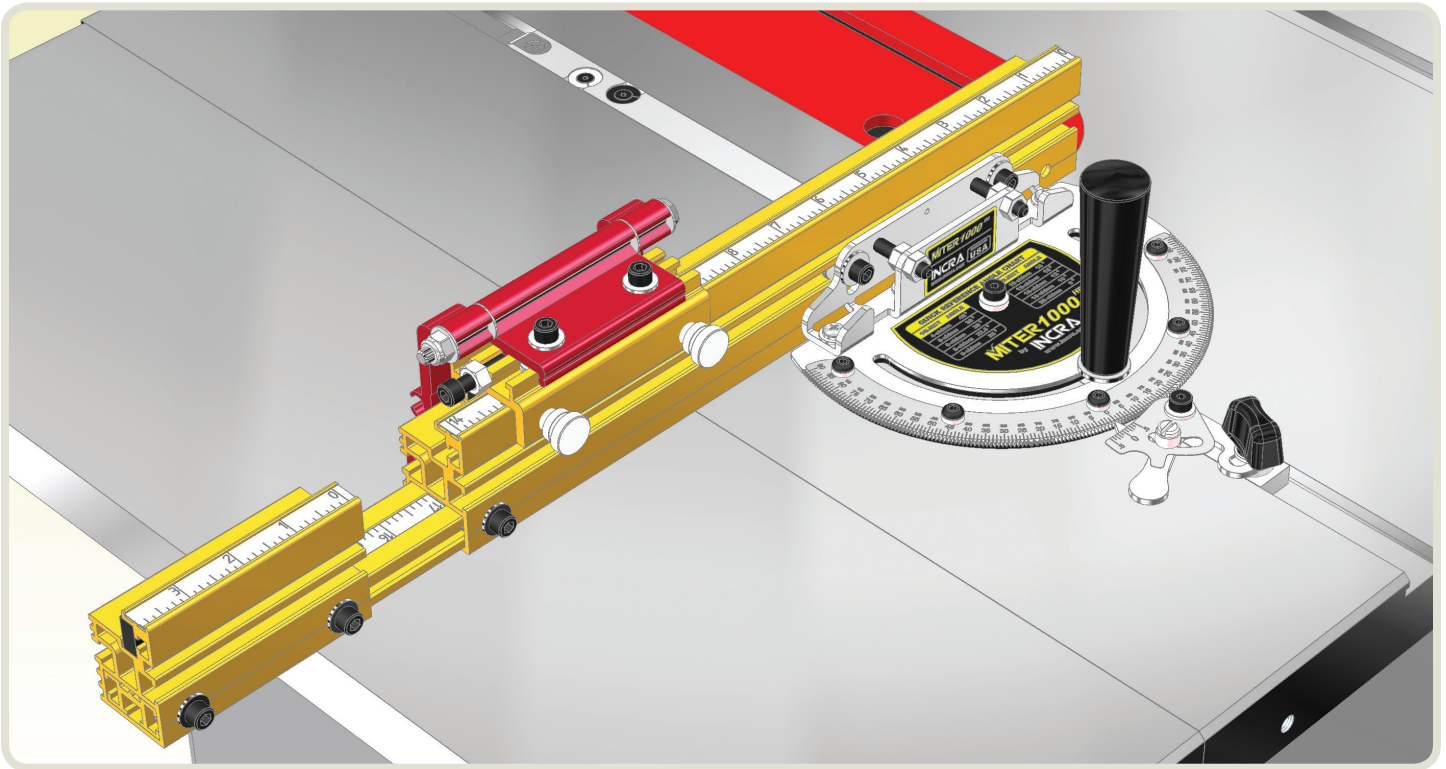

### **SAFETY:** IMPORTANT SAFETY INSTRUCTIONS FOR USING THE **INCRA MITER1000HD**



[WWW.INCRA.COM](http://WWW.INCRA.COM)

- When using the INCRA Miter1000HD in conjunction with any other tool, first read and follow all instructions and safety information in that tool's owner's manual.
- Never let the saw blade come in contact with the aluminum or steel components of the INCRA Miter1000HD.
- When using the INCRA Miter1000HD, always keep your hands clear of the saw blade and the line of cut.
- Always turn off the power and make sure that the saw blade comes to a complete stop before changing the setting of any part of the INCRA Miter1000HD.
- Always securely tighten the large black clamping knob before starting any cut.
- Wear safety glasses, hearing protection, and follow all normal shop safety practices.
- After making any adjustments to the miter angle or fence position of your INCRA Miter1000HD, always verify safe clearance between the blade and fence before turning on the saw.
- After making any adjustments to the fence position on the INCRA Miter1000HD, always make sure that the two socket head screws are securely tightened.
- When using the INCRA Flip Shop Stop to position a piece for a cut, always hold or otherwise clamp the board between the stop and the blade.

## Assembly and Calibration

### 1. Attach Clamping Knob and T-Clip

Remove the hex bolt that secures the protractor head and replace with the large threaded knob included in the hardware pack. The washer on the hex bolt must be used with the threaded knob, **Fig. 1**. If the Miter slot in your table saw has a T-slot, attach the T-clip to the end of the miter bar as shown in **Fig. 2**.

### 2. Adjust the Miter Bar

Loosen the (2) fasteners that secure the fence to the fence-mounting bracket and remove the fence. Adjust the miter bar at each of the (3) expansion mechanism locations in the miter bar for a good fit in your table saw's miter slot. Turning the screw clockwise expands the mechanism. You'll find (2) of the expansion locations in front of the protractor. Adjust these (2) front expansion points first, expanding a little at each of the locations until the bar slides smoothly, **Fig. 3**.

Remove the large clamping knob with washer and pivot the protractor head to gain access to the rear expansion point, **Fig. 4**. After adjustment, replace the washer and large clamping knob.

### 3. Attach the Fence

Place your Miter1000HD in the preferred miter slot at your table saw. (Note: Left hand miter slot use shown. See step 4 to convert fence for use in right hand miter slot.) Attach the fence to the fence mounting bracket and slide the fence to a position that leaves safe clearance between the end of the fence and the blade. Tighten the (2) 1/4-20 fasteners, **Fig. 5**.

**Fig. 1 Attach Clamping Knob**

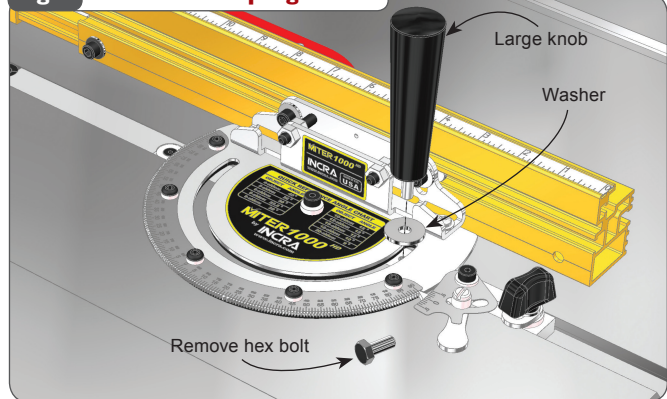

**Fig. 2 Attach T-Clip**

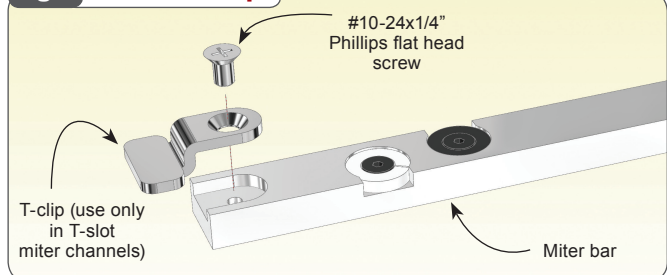

**Fig. 3 Expand Miter Bar to Fit (front)**

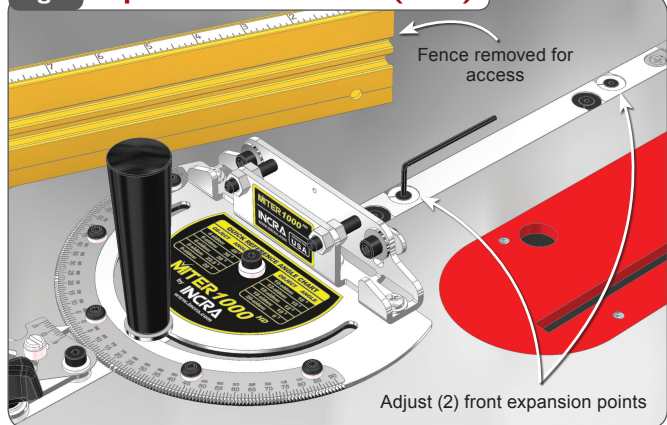

**Fig. 4 Expand Miter Bar to Fit (rear)**

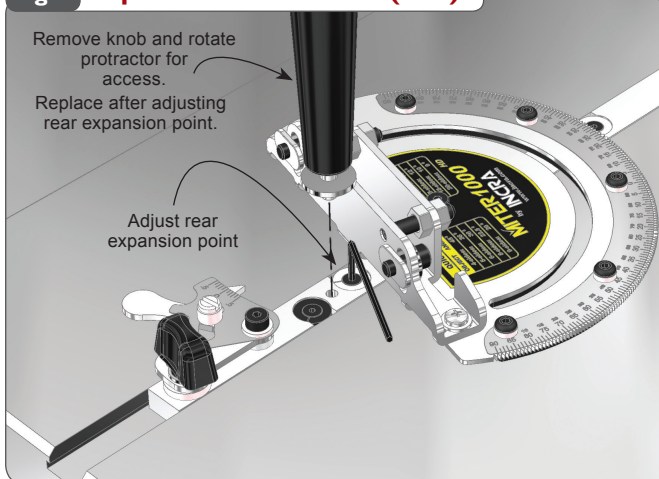

**Fig. 5 Attach Fence**

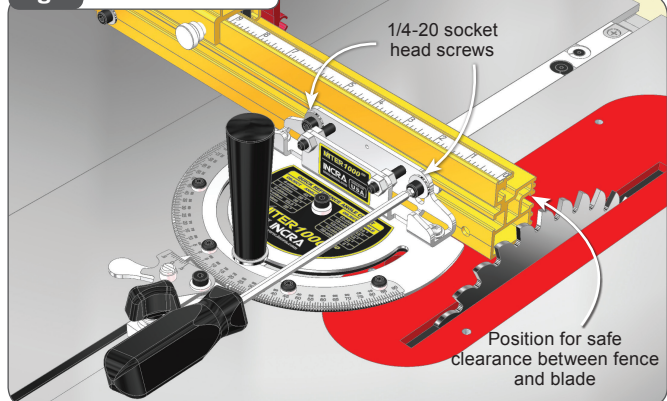



#### 4. Left or Right of Blade

Your new Miter1000HD fence is factory configured for use to the left of the blade. If you prefer to use your Miter1000HD in the right hand miter slot just follow the steps below.

Loosen the 1/4-20 socket head screw located at the end of the 14" section of the fence, then slide out the 4" section of fence along with the attached extender bar. Move the socket head screw, washer and rectangular nut to the hole on the opposite end of the fence. Slide the extender bar assembly into the end of fence, capturing the rectangular nut in the T-slot on the extender bar. The higher numbers on the extender bar scale should be closest to the saw blade. Loosen the (2) socket head fasteners that secure the 4" section of fence and reverse it. Tighten all fasteners, **Fig. 6**. Slide the scale in the top of the fence out and replace with the included reverse reading (0-14") scale.

**Fig. 6 Converting Fence for use on Right Side of Blade**

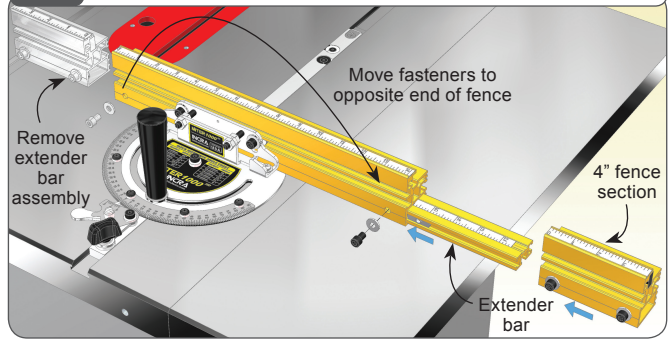

**Fig. 7 Set Protractor to 0°**

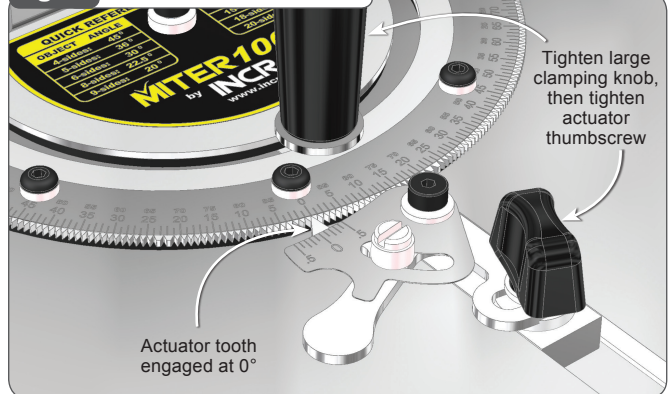

#### 5. Adjust Fence Mounting Bracket 90° to Saw Blade

Set the protractor head to read 0°, engaging the tooth on the actuator firmly into the 0° notch on the protractor head, **Fig. 7**. Tighten the large clamping knob then tighten the actuator thumbscrew.

Using a Phillips head screw driver, loosen the (4) Phillips head screws that secure the fence-mounting bracket to the protractor head. Unplug your table saw, then use a reliable machinist square to set the fence at 90° to the saw blade, **Fig. 8**. Tighten the (4) Phillips head screws.

**Fig. 8 Square Fence to Blade**



This one time calibration prepares your INCRA Miter1000HD for work in either miter slot. Just remember that the accuracy of the INCRA Miter1000HD at any subsequent setting is dependent upon the accuracy of your initial 90° calibration. **Verify this important calibration with a test cut and fine tune as necessary.**



**TIP**

#### SQUARING THE FENCE TO YOUR TABLE SAW TOP

Your INCRA Miter1000HD Fence has been adjusted square to the table at the factory so no further adjustment should be required. If adding a wooden sub-fence, fine adjustments to the angle can be easily made as described on Page 8.

## Operation – Changing Angle Settings

Before using your new INCRA Miter1000HD for the first time, take a few moments to review these important operational procedures.

### 1. 1° Indexing (including 22-1/2° settings)

Loosen the actuator thumbscrew and pivot the actuator tooth away from the notches located on the perimeter of the protractor head. Loosen the large clamping knob and rotate the protractor head and fence to the desired angle, **Fig. 9**. Then firmly engage the tooth on the actuator with the corresponding notch on the protractor head. The actuator tooth should point directly to the desired angle on the scale. Tighten the large clamping knob, then tighten the actuator thumbscrew, **Fig. 10**.

### 2. Continuous Adjustments (for angle settings finer than 1° increments)

Pivot the actuator tooth away from the notches on the protractor head and tighten the thumbscrew. Now loosen the small nylon thumbscrew on the actuator and pivot the 1/10° vernier cursor toward the scale. Rotate the cursor until it is aligned edge to edge with the scale and tighten the nylon thumbscrew. When you change miter angles, just align the desired angle on the scale with the “0” cursor line, **Fig. 11**. For 1/10° adjustments, use the alignments as described in the included 1/10° vernier cursor addendum.

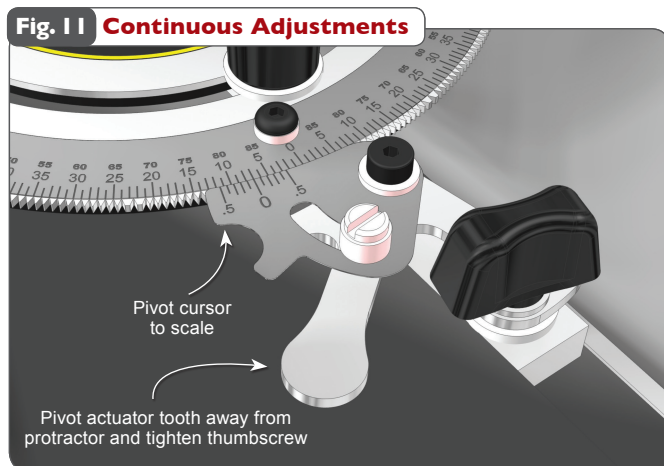
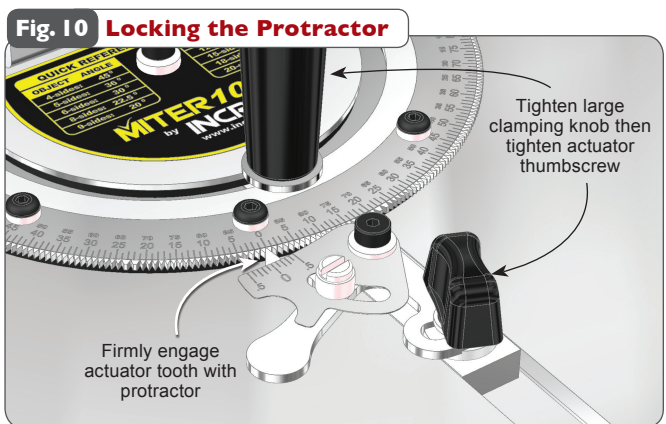
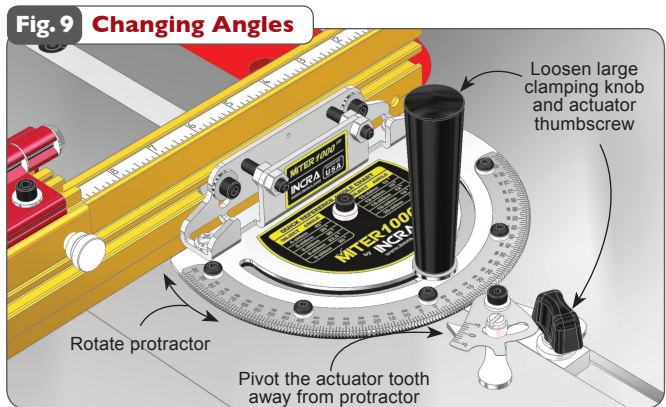
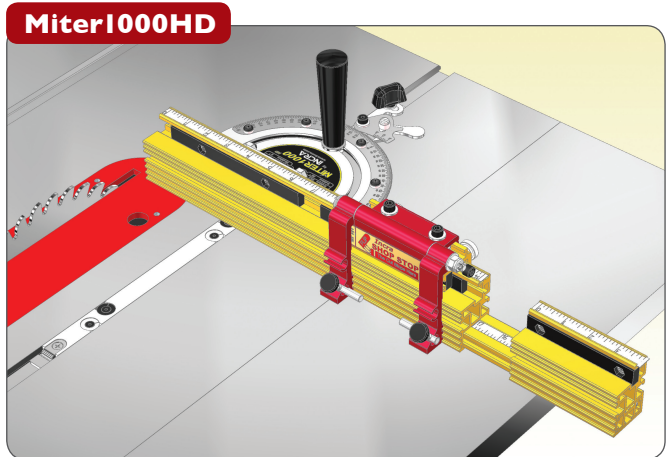

### CAUTION:

**AFTER MAKING ANY ADJUSTMENTS TO THE MITER ANGLE OF YOUR INCRA MITER1000HD, ALWAYS VERIFY SAFE CLEARANCE BETWEEN THE FENCE AND THE BLADE BEFORE TURNING ON THE SAW.**



## Flip Fence and Flip Shop Stop - Calibration and Operation

As you look at your new INCRA Flip Shop Stop and Flip Fence for the first time you will see an interesting detail. The front face of the fence uses a tongue and groove arrangement to accept a mating feature on the flip arms, **Fig. 12**. When the flip arm is down with the two opposing features engaged, it becomes impossible for the sharp corner of a mitered board end to wedge between the fence and flip arm. Combined with INCRA's famous incremental positioning capabilities, you'll soon be duplicating cut off lengths with machine shop precision.

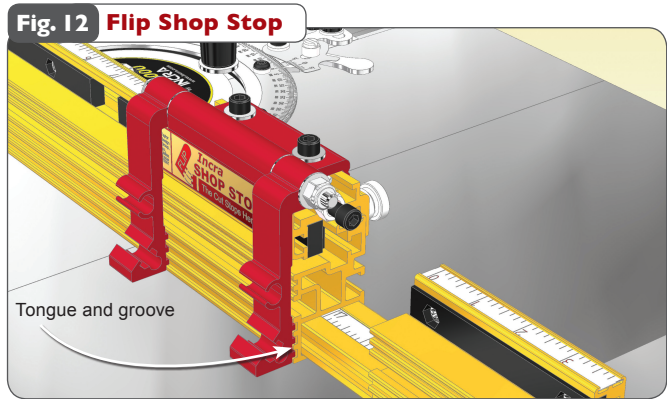

### Zeroing the Fence Scales

To zero the main fence scale for 90° work, first set the protractor to the 0° setting and lock in place. Clamp the Flip Shop Stop to the fence so that the 0" mark on the fence scale reads directly under the end of the gold component of the Flip Shop Stop, **Fig. 13**. Now loosen the (2) 1/4-20 socket head screws that secure the fence to the fence mounting bracket and slide the fence toward the blade until the Flip Arm on the stop contacts the blade. Re-tighten the fasteners, **Fig. 13A**.

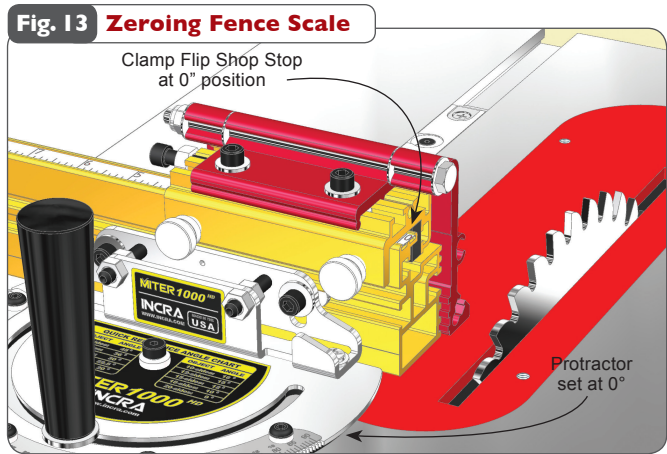

For stopped cuts beyond the range of the main fence you'll need to calibrate the extender bar scale. Clamp the INCRA Flip Shop Stop to the 4" fence extender. (Use the scale on the short section of fence as a reference for clamping the stop to the same position each time you use it.) Now loosen the 1/4-20 socket head screw located at the end of the longer fence and slide the 4" fence and extender bar out. Use a tape measure to set the distance between the blade and the flip arm at 16" and re-tighten the fastener, **Fig. 14**. Now simply slide the scale in the extender bar to read 16" at the end of the longer main fence section, **Fig. 14A**.

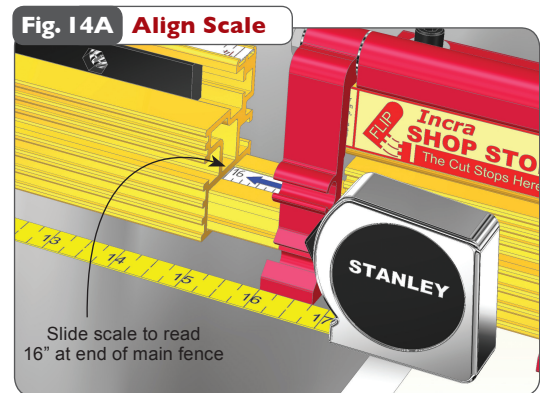
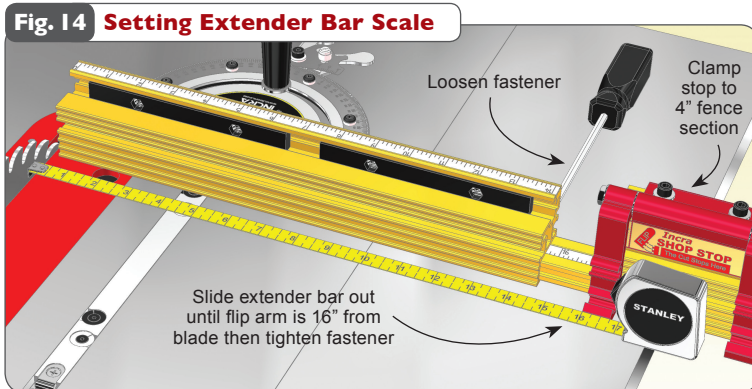
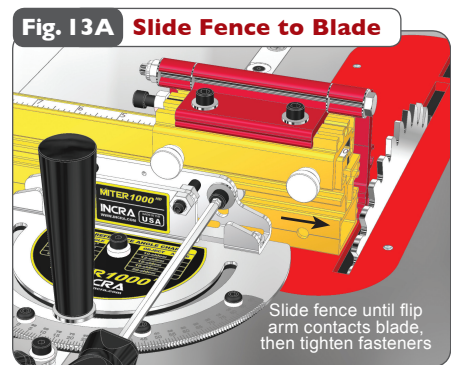

For mitered cutting, a test cut is often the most accurate means of setting the fence and extender bar scales since measuring to the tooth of a blade set at an angle to the fence can be difficult. Begin by setting the desired miter angle and check for safe clearance between the fence and blade. Clamp the stop to the fence about 10" away from the blade. Miter a piece of scrap stock with this setup. Measure the length of the cut piece, **Fig. 14B**. Then simply slide the scale on the fence to read the length of the cut directly under one end of the stop.

**Fig. 14B Setting Scales for Angled Cuts**

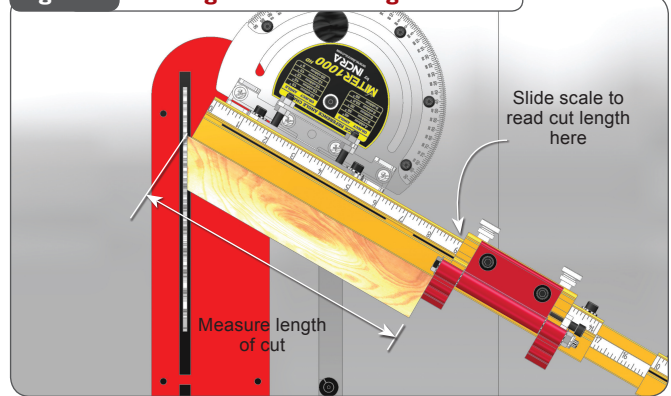

**Micro Adjusting**

To micro adjust your Flip Shop Stop's position, begin by loosening the (2) socket head screws located on the top of the stop body. Now turn the micro adjust socket head screw to fine tune the stop position, **Fig. 15**. When unscrewing the micro adjust screw, apply pressure to the stop body to keep it against the screw end. After adjustment, always tighten the (2) socket head screws on top of the stop body.

**Fig. 15 Micro Adjusting**

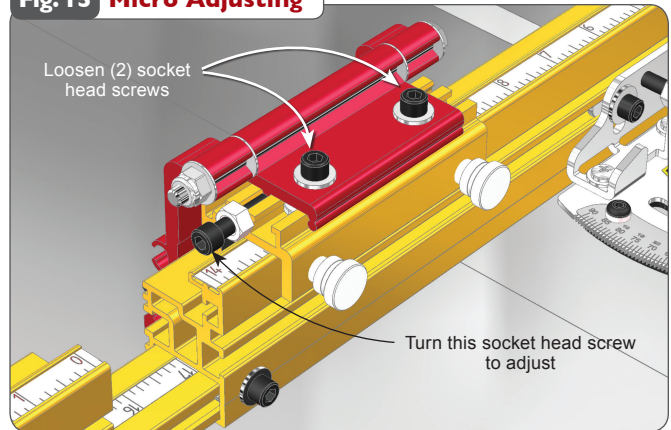

**Flip Arms and Stop Rods**

The dual flip arms and stop rods provide a variety of stop configurations. The flip arms can be used without the stop rods when you want to take advantage of the fence/arm tongue and groove feature for stop control on mitered board ends. Typically, you will use the longer rod to join the two arms together, **Fig. 16**. This produces an arrangement that, when pivoted, moves both arms simultaneously. The rod can be positioned so that it is the actual stop surface or it can be positioned slightly behind the front of the arm so that the aluminum arm is the actual stop surface.

**Fig. 16 Long Stop Rod**

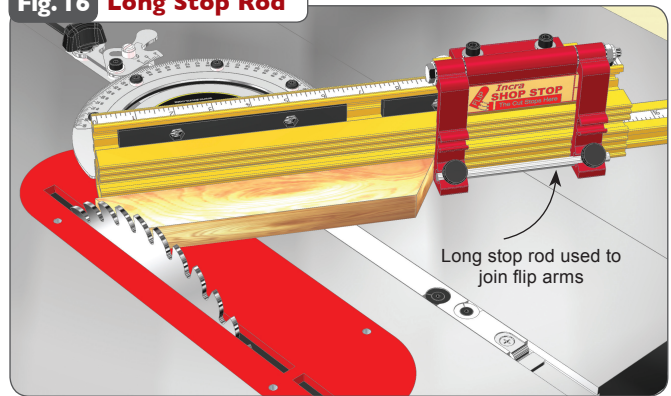

By placing one of the shorter 1-1/2" rods in each of the two stop arms, you can use the two stop arms independently, **Fig. 17**. For example, you can calibrate one for work to the left of the blade and the other for work to the right. On one side of the blade you might want to position the stop rods to provide two different cut off lengths from one stop position. By using varying combinations of long or short rods you can create as much as 7-3/4" between the two stop positions.

**Fig. 17 Short Stop Rods**

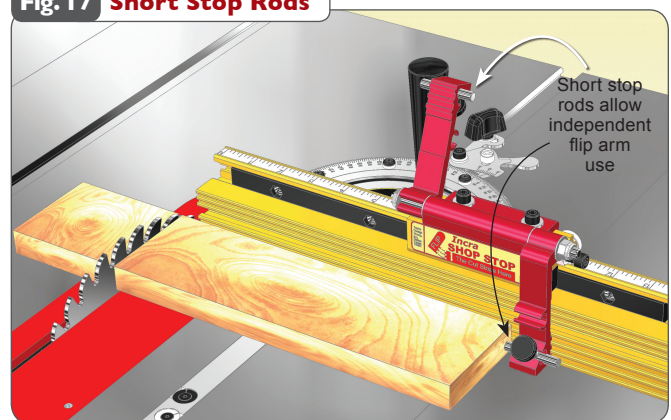



### Making a Zero Clearance Wooden Sub Fence

A sub fence can be used to provide tear out control as well as support for your workpiece up to and beyond the blade. A good material to use for making your zero clearance sub fence is 3/4" medium density fiberboard (MDF). Use the drill and counter bore dimensions shown in **Fig. 18**. Attach using the supplied fasteners. Adjust the length of the fence to accommodate your application. Note: In applications where the incremental stopping capability of the Flip Shop Stop is required, the wooden sub fence can be no taller than 2-1/2".

**Fig. 18 Making a Sub Fence**

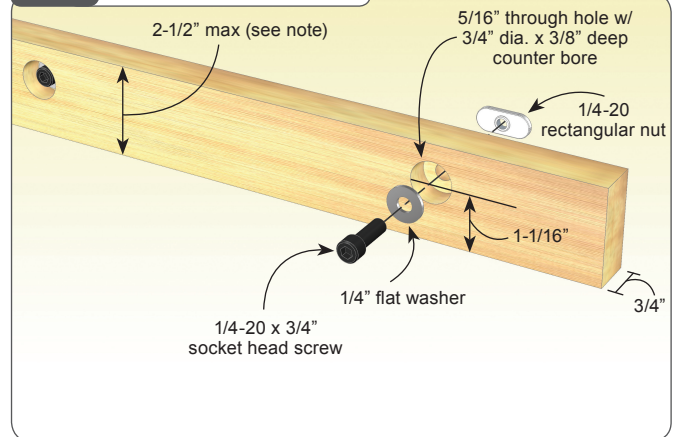

### TIP

To avoid the saw blade pulling your workpiece into the cut, add a strip of adhesive backed sandpaper to the front face of the wooden sub fence.

### Expanded Flip Stop Clamping Mode

The two-part body design of the INCRA Flip Shop Stop allows for use with up to a 3/4" thick wooden sub fence. To expand the INCRA Flip Shop Stop, loosen the (2) socket head screws located on the top of the stop body, then slide the upper portion of the stop off. Now slide the upper portion back on, capturing the rectangular nuts in the second T-slot located on the lower portion (gold component) of the stop body, **Fig.19**.

**Fig. 19 Expanded Flip Stop Clamping Mode**

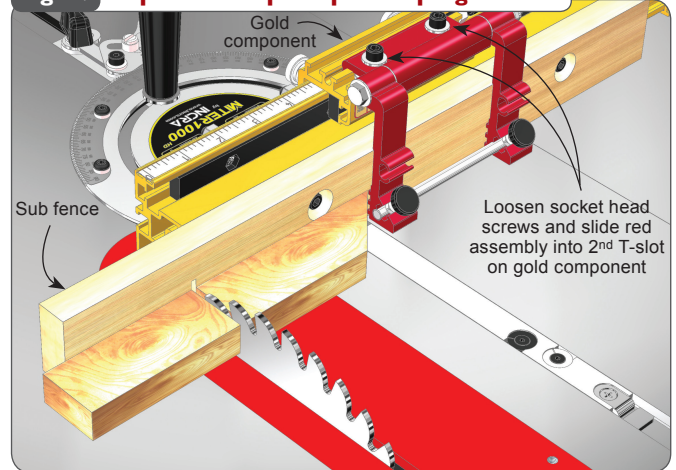

## WARRANTY

TAYLOR DESIGN GROUP, INC. WARRANTS THIS PRODUCT FOR ONE YEAR FROM DATE OF PURCHASE. WE WILL REPAIR ANY DEFECTS DUE TO FAULTY MATERIAL OR WORKMANSHIP, OR AT OUR OPTION, REPLACE THE PRODUCT FREE OF CHARGE. PLEASE RETURN THE FAILING COMPONENT ONLY, POSTAGE PREPAID, ALONG WITH A DESCRIPTION OF THE PROBLEM TO THE ADDRESS BELOW. THIS WARRANTY DOES NOT APPLY TO PARTS WHICH HAVE BEEN SUBJECTED TO IMPROPER USE, ALTERATION, OR ABUSE.

### LIFETIME WARRANTY ON POSITIONING RACKS

IF AN INCRA POSITIONING RACK IN THIS TOOL BECOMES DAMAGED FOR ANY REASON, TAYLOR DESIGN GROUP WILL REPLACE IT FREE OF CHARGE FOR AS LONG AS YOU OWN YOUR TOOL. RETURN THE DAMAGED RACK, POSTAGE PREPAID, PLEASE ALLOW 1 TO 2 WEEKS FOR DELIVERY.

## Adjustable Fence Mounting Bracket

Your **INCRA Miter1000HD Fence** has been adjusted square to the table at the factory so no further adjustment should be required. If adding a wooden sub-fence, fine adjustments to the angle can be easily made as described below.

Incra's fence mounting bracket enables any fence to be quickly and easily adjusted for perfect squareness to the table. We have provided two adjustment points so you can also neutralize twist or thickness variation that is sometimes present in homemade wooden fences or sub-fences.

1) Place a square against the front face of your fence. If you see a gap between the top of the fence and your square first loosen both outside nuts. Tighten one of inside nuts about 1/6 turn against the rear leg of the bracket as shown in **Figure 20**, and then tighten the other inside nut by the same amount in the same direction against the rear leg. Alternate this 1/6 turn procedure between the two nuts until the fence is perfectly square to the table. **DO NOT TURN THE SET SCREW** and **DO NOT** over tighten the nuts. It usually takes less than 1 full turn of the nuts to square your fence to the table.

If you see a gap between the bottom of your fence and the square, first loosen both inside nuts. Tighten one of outside nuts about 1/6 turn against the rear leg of the bracket as shown in **Figure 21**, and then tighten the other outside nut by the same amount in the same direction against the rear leg. Alternate this 1/6 turn procedure between the two nuts until the fence is perfectly square to the table. **DO NOT TURN THE SET SCREW** and **DO NOT** over tighten the nuts. It usually takes less than 1 full turn of the nuts to square your fence to the table.

2) After the fence has been squared to the table as described above, tighten both of the loose nuts against the rear leg of the bracket to secure your setting, **Figure 22**. **DO NOT TURN THE SET SCREW**.

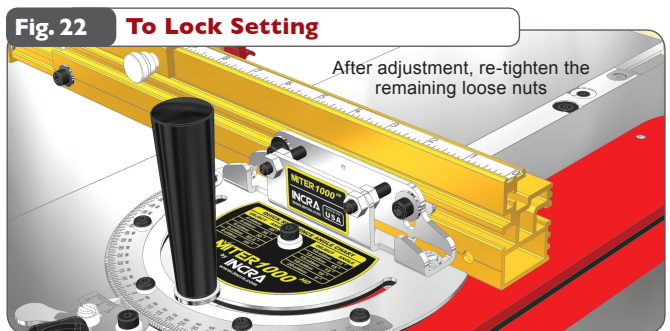
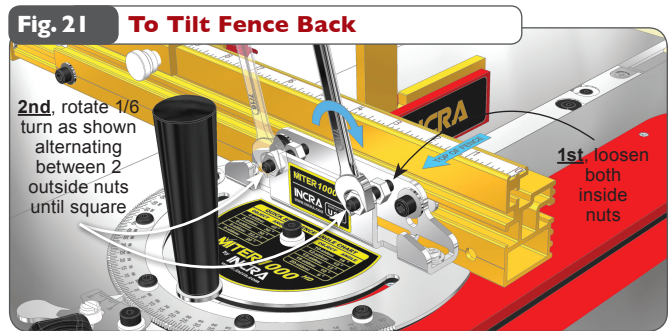
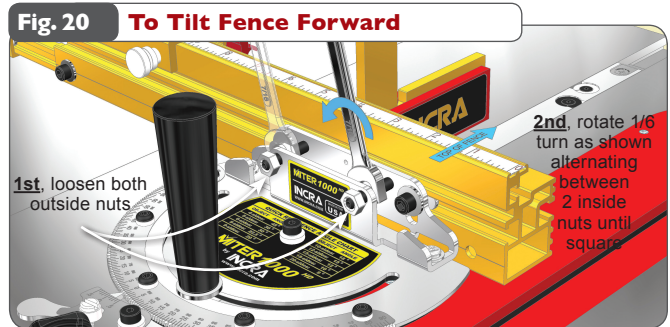

Manufactured by:  
Taylor Design Group, Inc.  
P.O. Box 810262 Dallas, TX 75381  
[www.incra.com](http://www.incra.com)  
P: 972-242-9975/F: 972-242-9985



INCRA is a Registered Trademark of Taylor Design Group, Inc.

### ONLINE WARRANTY REGISTRATION

Scan this QR code to register your product online ▶



You can also register your INCRA product online at [www.incra.com](http://www.incra.com)

*It's quick and easy!*